

Crown Bevcan, Europe & Middle East

www.crowncork.com

Status: **Approved**

Issue Date: **28 March 2018**

Version Number: **2**

Authorised By: **Florent Gourven**

Component Weight :	2.49g
Compound Weight :	21mg +/- 6
Nominal Material Thickness :	0.208mm
Component Lacquered Material Thickness :	0.218mm nom.
Minimum Peaking Pressure :	6.2bar
Minimum Vent Pressure :	6.2bar
Internal Lacquer Specification :	PVC Free
External Lacquer Specification :	Epoxy
Lining Compound Specification :	Water Based
Compound Placement :	High on Shoulder (HOS)
Stacking Rate :	26 +/- 2 per 50.8mm



202 ISE - LOE
Large Aperture

End Specification

Entity Code	Entity Description	Value	Tolerance
ED	Curly External Diameter	59.33 mm	±.25
EL	Curly Tip Diameter	57.66 mm	min.
EB	Curly Height	1.98 mm	±.15
HK	Converted Countersink Depth	6.17 mm	±.13
EJ	Compound Shoulder Clearance	5.60 mm	±.50
EK	Compound Edge Clearance	1.00 mm	±.50

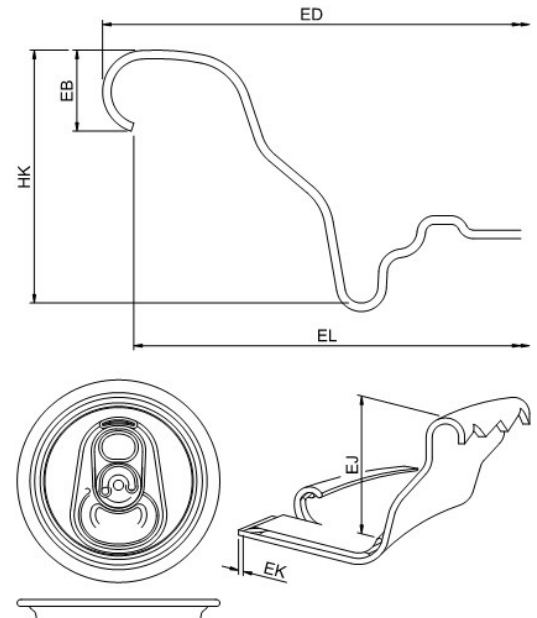

Crown Bevcan, Europe & Middle East

www.crowncork.com

Status: **Approved**

Issue Date: **28 March 2018**

Version Number: **2**

Authorised By: **Florent Gourven**

Plants		
Country	Name	Options
Spain	Agoncillo	
<input type="text"/>	<input type="text"/>	